

# FORMING GUIDE

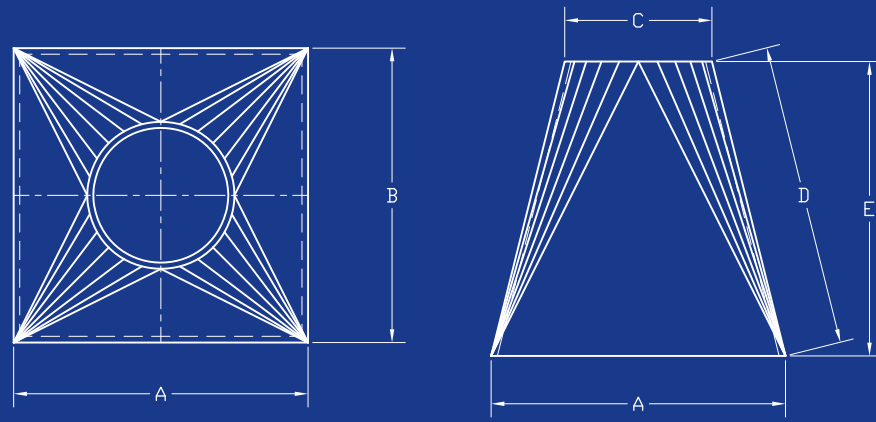

25



26

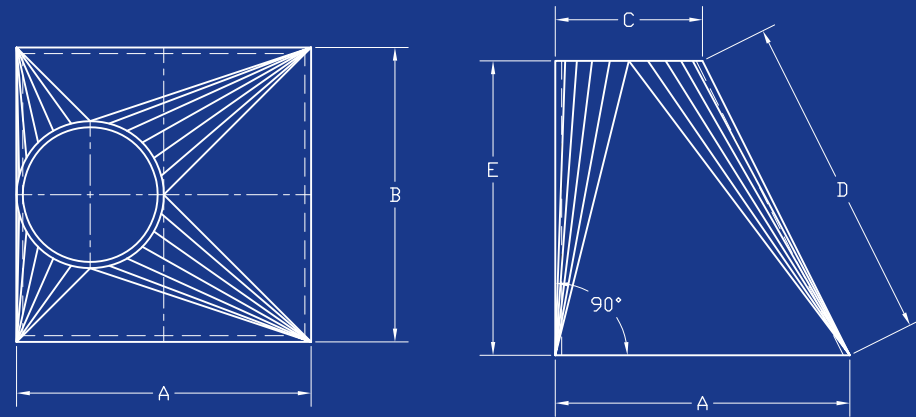

27

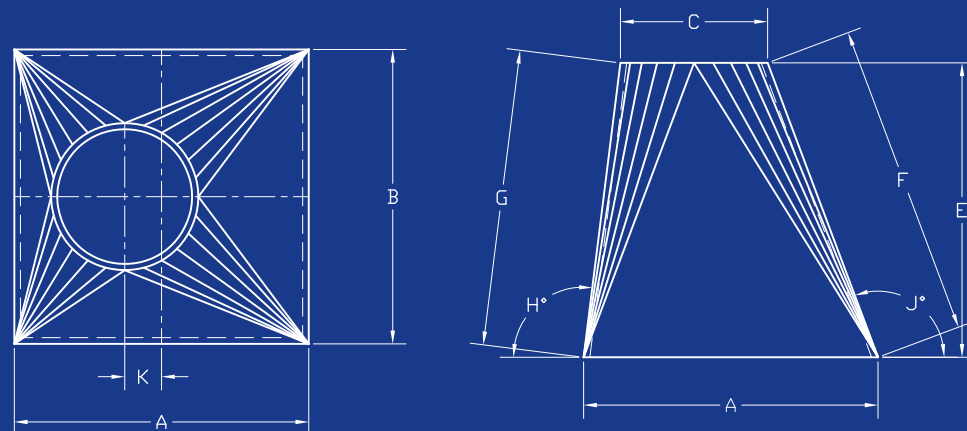

## INFORMATION REQUIRED

1. Shape #
2. Material Type & Thickness
3. Quantity
4. Length of Part
5. Outside or Inside Dimensions Provided
6. Tolerances & Critical Dimensions

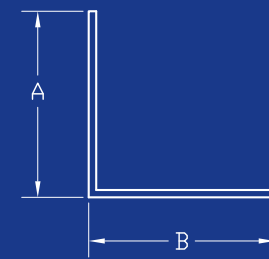

1

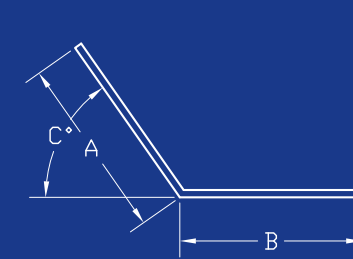

2

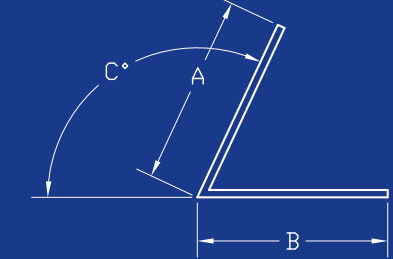

3

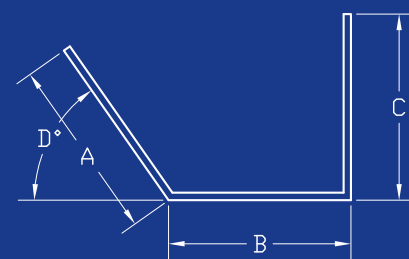

4

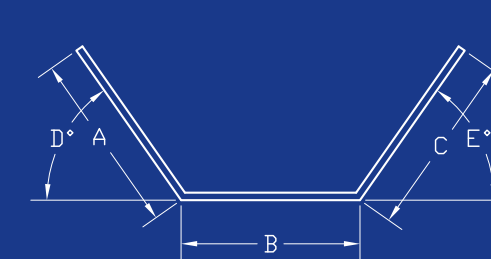

5

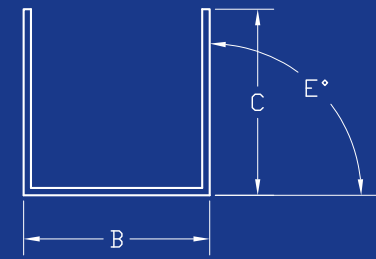

6

